

Washer extractor

W5130S

Features and benefits

- **Compass Pro[®] microprocessor offers:**
 - Large display and one control knob for easy program selection
 - Language selection
 - Quick selection and option buttons for the most frequently used wash programs and options
 - Wash program packages optimized on Economy, Performance and Time. (Available on general programs)
- **AS – Automatic Savings:**
 - The machine weighs the linen and adjusts the amount of water and energy according to the load. This leads to considerable savings in case the machine is not fully loaded. (Available on general programs)
- Extremely low water and energy consumption – see table below
- Four compartment detergent box for manual dosing of powder or liquid detergent
- High extraction force for efficient dewatering
- Door with gasket and strong hinges built for heavy duty operation
- Stainless and galvanized steel in all vital parts for high degree of rust protection
- SuperBalance guarantees the correct extraction force



Images shown are a representation of the product only and variations may occur.

Main options

- Automatic liquid detergent supply (optional I/O board)
- Connection to booking- /payment- system or coin meter

Main specifications				W5130S			
Max. capacity	filling factor 1:9	kg/lb		14/30			
Drum, volume		litre		130			
	diameter	ø mm		595			
Extraction		rpm		776			
G-factor				200			
Standard heating alternatives	electricity	kW		7.5 / 10.0			
Low energy heating alternatives	electricity	kW		3.0			
	steam			X			
	non-heated			X			
Consumption data "Normal 60°C"				EI		Steam***	
Economy*				Full load, 14 kg	Half load**, 7 kg	Full load, 14 kg	Half load**, 7 kg
Total time		min	50	45	50	45	
Water consumption (cold+hot)		litre	91+23	44+12	114+0	56+0	
Energy consumption (motor/heating/hot water)		kWh	0.2/0.65/1.45	0.2/0.35/0.75	0.2/-	0.2/-	
Steam consumption		kg	-	-	3.2	1.7	
Residual moisture		%	58	66	58	66	
* Water temperature 15°C cold water and 65°C hot water.							
** Programs with AS.							
*** Depending on steam pressure.							

Produced according to ISO 9001 and ISO 14001.

Certified with CB certificate for Low Voltage Directive and S-mark according to the Machinery Directive. Protection class IP X4D.

Electrical connections					
Heating alternative	Main voltage	Hz	Heating power kW	Total power kW	Recommended fuse A
Steam or Non heated	220-480V 1 -	50/60	-	1.0	10

Water and steam connection		W5130S	
Water valves	DN	20	
Water pressure	kPa	200-600	
Capacity at 300 kPa	l/min	20	
Drain valve	∅ mm	75	
Draining capacity	l/min	170	
Steam valve	DN	15	
Steam pressure	kPa	300-600	
Liquid detergent supplies		5	
Floor requirements			
Frequency of the dynamic force	Hz	12.9	
Floor load at max extraction	kN	2.3 ± 3.8	
Sound levels			
Sound power/pressure level at extraction*	dB(A)	70/56	
Sound power/pressure level at wash*	dB(A)	62/47	
Heat emission			
% of installed power, max		5	
Shipping data**			
Weight	net, kg	154	
Shipping volume	m ³	1.02	
Accessories			
Steel base		x	
Hose kits for water or steam		x	
Fluff collector		x	
Dimensions in mm			
A	Width	720	
B	Depth	787	
C	Height	1216	
D1		367	
D2		424	
E		1337	
F		920	
G		80	
H		1119	
I		217	
J		124	
K		1099	
L		999	
M		278	
N		103	
O		212	
1	Operating panel	7	Drain
2	Door opening ∅ 365 mm	8	Liquid detergent supply
3	Detergent box	9	Electrical connection
4	Cold water	10	Steam connection
5	Hot water		
6	Re-used water		

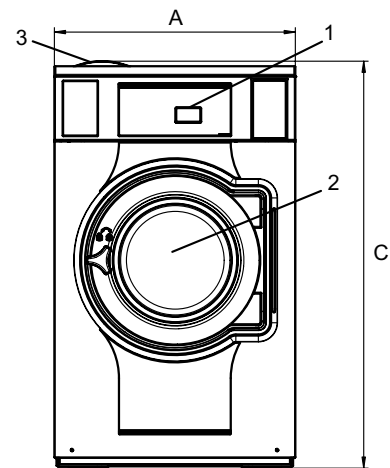

Front

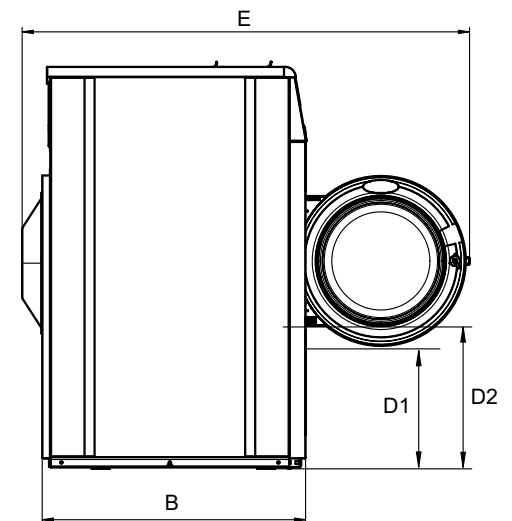

Side view

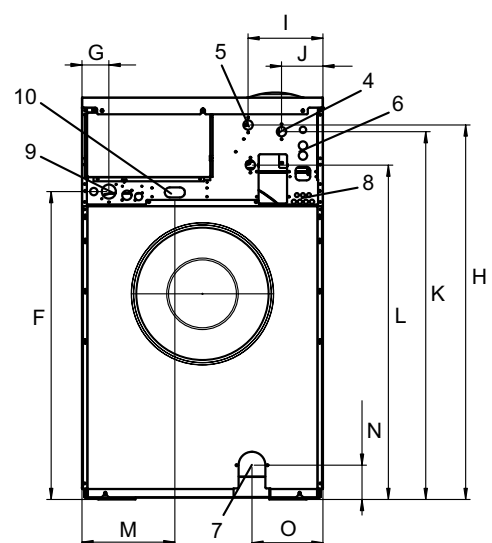

Rear

Front and side panels in light grey and blue (RAL 260 70 05, 250 60 30)

* Sound power levels measured according to ISO 60704.

** Average data. Crated weight/shipping volume depends on configuration. Please contact logistics for exact measures.