

HIGH EFFICIENT SOFT MOUNTED WASHER EXTRACTORS

**FX
RANGE**

FX 180

20kg

FX 240

27kg

FX 280

32kg



FEATURES

- Freestanding, high spin
- Stainless steel top panel & Anthracite grey front and side panels
- Stainless steel drum and tub
- Xcontrol - easy to use microprocessor
- Patented Soap Hopper
- High capacity water inlets (FX280)
- Large drain valve (Ø 76 mm)
- Easy access to all vital parts from the front
- Large door opening for easy loading & unloading

OPTIONS

- Xcontrol Plus - Fully programmable
- Coin operated timer (CPS)
- Stainless steel front and side panels
- USB & RS485 plug (on the back panel)
- Easy Soap - liquid soaps connection
- Liquid soap pumps
- Water recovery kit
- Steam heating version
- 3rd water inlet
- High capacity water inlets (FX180, 240)
- OptiLoad weighing system (only with Xcontrol+ programmer)
- Water sample tap (FX280)



ERGONOMICAL
CONSTRUCTION



LARGE DOOR
OPENING



LOW WATER
AND ENERGY
CONSUMPTION



TYPE		FX180	FX240	FX280
INNERDRUM				
maximum capacity 1:9	kg	20	27	32
capacity 1:10	kg	18	24	28
volume	litres	180	240	280
diameter	mm	750	750	750
DRUM SPEED				
wash	rpm	42	42	42
extraction	rpm	980	980	915
G-FACTOR				
		400	400	350
HEATING				
electricity (standard)	kW	12 / 18	18	18 / 21,9
steam	bar	1-8	1-8	1-8
hot water	°C	90	90	90
Sound pressure level	dB (A)	< 65	< 65	< 65
Water valves connection	BSP	3/4"	3/4"	3/4"
Water pressure	kPa	100-800	100-800	100-800
Rec. water pressure	kPa	300-500	300-500	300-500
Water inlet	l/min	20	20	20-50
Drain valve	outer Ø mm	76	76	76
Flow amount with drain valve	l/min	210	210	210
Steam valve connection	BSP	1/2"	1/2"	1/2"
Steam pressure	kPa	100-800	100-800	100-800
DIMENSIONS				
Size HxWxD	mm	1410x970x970	1410x970x1105	1410x970x1185
Net weight	kg	380	430	495
TRANSPORT DATA				
Packed HxWxD	mm	1550x1025x1015	1550x1025x1150	1550x1025x1225
Gross weight	kg	395	450	515

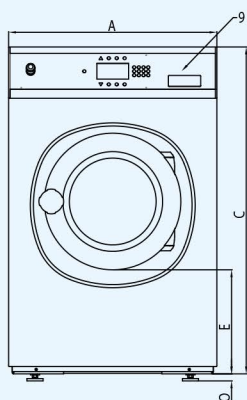

Front side

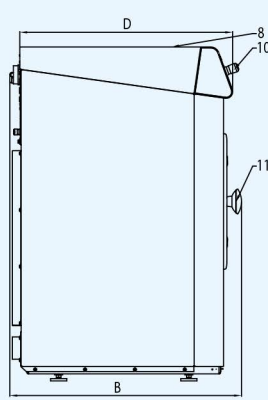

Left side

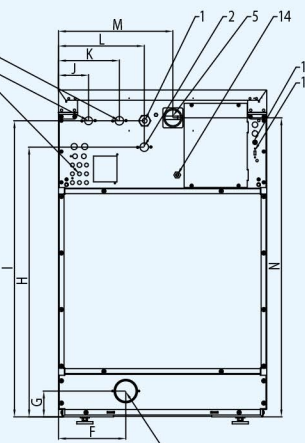

Rear side

- 1 Electrical connection
- 2 Hot water
- 3 Cold water hard
- 4 Cold water soft
- 5 Main switch
- 6 Liquid soap connection
- 7 Drain
- 8 Soap dispenser
- 9 Control panel
- 10 Button CENTRALSTOP
- 11 Door opening Ø 460mm
- 12 Fuses
- 13 USB port
- 14 Electrical connection to liquid soap pumps

DIMENSIONS

	A	B	C	D	E	F	G	H	I	J	K	L	M	N	O
FX180	970	970	1410	906	477	270	108,5	1215	1297,5	102,5	208	293	610	1315	24
FX240	970	1105	1410	1041	477	270	108,5	1215	1297,5	102,5	208	293	610	1315	24
FX280	970	1185	1410	1116	477	270	108,5	1215	1305	102,5	208	293	610	1315	24
	width	depth	height												

VISIT OUR WEBSITE www.totalce.com.au
CALL US ON 1300 355 769



Complete Project Solutions™



WATCH THE FX VIDEO

www.bit.ly/videofx



The Primus preserves the right to change the machines and the specification in this leaflet at any time, without prior notice. Details and photographs are only for information and never binding.

www.primuslaundry.com

