

Washer extractor

W4850H, W41100H

Features and benefits

- Clarus Control[®] – programmable microprocessor with 9 fixed and up to 192 programs to allow free programming
- High extraction for efficient dewatering
- Frequency-controlled motor for optimal washing
- Supplied with 8 + 5 signals for liquid detergents
- Eight connections for liquid detergents
- Large door opening for easy loading and unloading
- All critical parts made from stainless steel to provide a high level of corrosion resistance
- Powder painted galvanised steel side panels
- Bearing seals lubricated with oil to ensure a long service life. Empty container alarm
- Direct steam heating.
- Low noise level for pleasant working environment
- Designed for easy servicing and maintenance

Main options

- Forward or forward/backward tilting with full reversing function
- Noise/heat insulation
- Test tap with level tube
- Two drain valves for recovering water/wash solution
- Five-compartment injector for powder detergent (located at the front or on the right hand side of the machine)
- Third water valve
- Large water valves
- IS - Integrated Saving
- Connection for intelligent detergent system (DMIS)
- Connection to CMIS



Images shown are a representation of the product only and variations may occur.

Main specifications		W4850H	W41100H
Max. capacity	kg/lb	90/200	120/250
Drum, volume diameter	litre	850	1100
	ø mm	1220	1220
Extraction	rpm	720	663
G-factor		350	300
Heating alternatives	steam	x	x
	non-heated	x	x
	electricity	-	-
Consumption data "Normal 60°C" *			
Total time (cold+hot/cold)	min	45/50	45/50
Water consumption (cold/hot)	litre	713/125	850/153
Energy consumption (motor/heating)	kWh	2.3/-	2.4/-
Steam consumption (cold/hot)	kg	10	12
Steam consumption (cold)	kg	19	23

* Water temperature 15°C cold water and 65°C hot water.

Electrical connections*		W4850H	W41100H
Steam or non-heated	200V 3AC 60 Hz kW(A)	6.7 (35)	5.3 (35)
	230V 3AC 50 Hz kW(A)	6.7 (25)	5.3 (25)
	230V 3AC 60 Hz kW(A)	6.7 (20)	5.3 (20)
	400-415V 3N AC 50 Hz kW(A)	6.7 (16)	5.3 (16)
Water, steam and air connections			
Water valves	DN	32	32
Rec. Water pressure	kPa	200-600	200-600
Function limits for water valve	kPa	50-1000	50-1000
Capacity at 300 kPa	l/min	150	150
Drain valve	ø mm	110	110
Draining capacity	l/min	400	400
Steam valve	DN	32	32
Rec. Steam pressure	kPa	300-600	300-600
Function limits for steam valve	kPa	50-800	50-800
Compressed air	DN	6	6
Air pressure	kPa	500-700	500-700
Air consumption	l/h	20	20
Five-compartment detergent injector	DN	20	20
Floor requirements			
Frequency of the dynamic force	Hz	12.0	11.1
Floor load at max extraction	kN	25.9 ± 1.5	27.9 ± 2.0
Sound levels			
Sound level	dB(A)	73	73
Sound level, with insulation	dB(A)	< 70	< 70
Heat emission			
% of installed power, max 90°		6.7	6.8
Shipping data			
Shipping volume	net, kg	2200	2300
	m ³	7.6	8.4

* Other voltages available, see installation manual.

Dimensions in mm	W4850H	W41100H
A Width	1640	1640
B Depth	1635	1850
C Height std/tilt+IWS	2190/2230	2190/2230
D std/tilt+IWS	955/995	955/995
Ea	300	300
Eb	380	380
F std/tilt+IWS	2095/2135	2095/2135
G	1070	1070
H	830	830
I	635	635
K	445	445
L	1140	1140
M std/tilt+IWS	1620/1660	1660/1660
N std/tilt+IWS	395/435	395/435
O	820	820
P	2410	2400
R	1175	1160
S	2480	2480
T	960	955
U	285	240
V	400	335

- 1 Control panel
- 2 Door opening \varnothing 700 mm
- 3a Five-compartment detergent injector for powder detergent, front (optional)
- 3b Five-compartment detergent injector for powder detergent, right hand side (optional)
- 4 Cold water connection
- 5 Hot water connection
- 6 Third water connection (optional)
- 7 Steam connection
- 8 Drain
- 9 Electrical connection
- 10 Compressed air connection
- 11 External liquid detergent injector, 6 pcs \varnothing 10, 1 pc \varnothing 16 and 1 pc \varnothing 20
- 12 Water connection, detergent injector (optional)

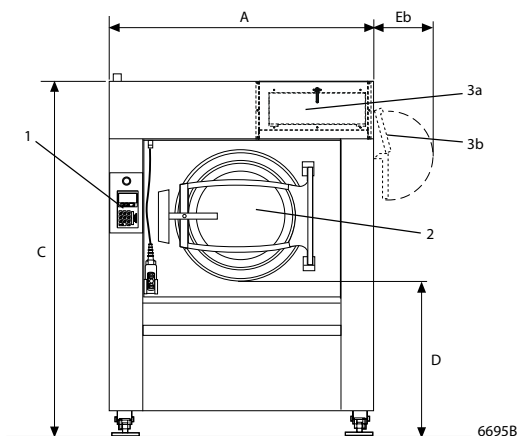

Front

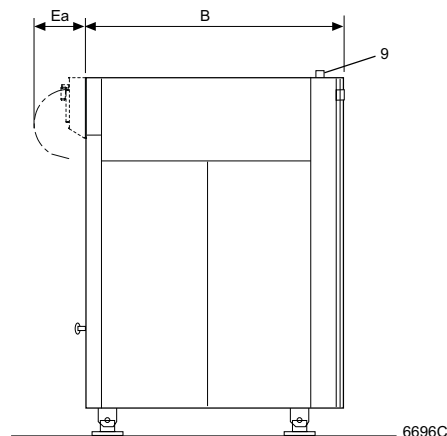

Right side

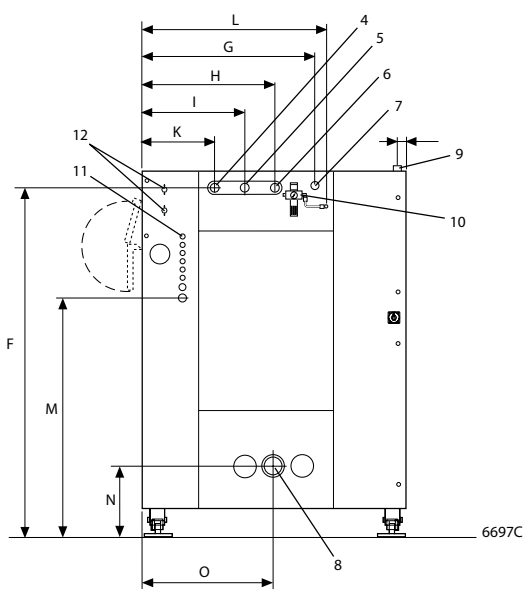

Rear side

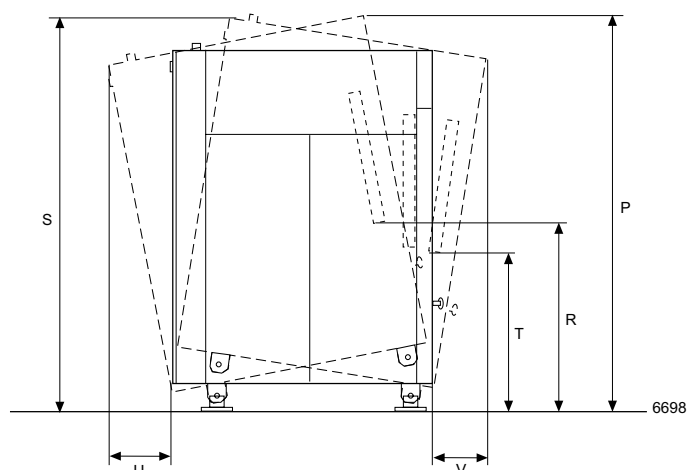

The movement when tilting

Options

- Forward or forward/backward tilting with drum reversal – makes unloading into a trolley easy.
- Noise/heat insulation – reduces airborne noise to less than 70 dB(A).
- Test tap with level tube – allows you to take samples from the wash solution.
- Water/wash solution recovery system – two drain valves allow you to recover rinse water and re-use it in the wash.
- Five-compartment injector for powder detergent
Option 1, (5x1 litre), located on front of the machine.
Option 2, (5x2 litres), located on right hand side of the machine.
- Water inlet via pump – additional water inlet for water via pump from recovery system.
- Third water valve – electrically-controlled water valve for hard water.
- Steam connection components.
- Connection components for 2 water connections.
- Connection components for 3 water connections.
- Pump inlet connection components. Recovery
- IS – Integrated Saving
- Connection for intelligent detergent system (DMIS).
- Large water valves (DN 50 / 2" BSP) (DN 40 / 1 1/2" BSP).
- May be included in a hands-off system.
- Kit for connection to CMIS (Certus Management Information Systems) network.

Accessory

- WPM PC program. Allows the creation of wash programs on a PC and their transference to the machine via a memory card.



CMIS can be fitted to washer extractors with Clarus Control, tumble dryers with Selecta Control and ironers with electronic control system. All you need to access and view the statistical feedback is a normal PC.