

## TUMBLE DRYERS

DESIGNED TO MEET ALL NEEDS

## DD23 SILVER/BRONZE

### FEATURES

- Construction in grey skinplate, stainless steel look.
- Big loading door (opening of 180°).
- Direct drive through a gearbox, no pulley.
- **DD BRONZE range:** Analogic control with time and temperature selection. Light indication of heating. (These models do not allow the moisture control option).
- **DD SILVER range:** Electronic control. Easy and intuitive to use, the electronic control offers a complete control of the process.
- **REVERSING DRUM:** All models offer the reverse turning of the drum.
- **STAINLESS STEEL DRUM** standard.
- **DOUBLE FLOW:** Mixed axial-radial airflow to optimise and maximise the airflow circuit in the drum.
- **GENTLE DRY:** The new drum with stamped holes makes sure the linen is gently handled.
- New filter drawer with wide surface and improved airflow.
- **Cool Down:** Anti-wrinkle at the end of cycle.
- Models available in electric, gas or steam heating.
- **Self-Service:** SILVER range have several payment options for Laundromats: to work with centralized payment systems, with coin / token, or with prepay card systems. Electric and gas heated models.



### OPTIONS

- **CARE DRY:** Intelligent Moisture Control. (SILVER range).
- **SPRINKLER:** Integrated Fire Extinguishing System. (SILVER range).
- Double doorglass.
- Stainless steel body.
- Stainless steel front panel.
- Low pressure steam battery.
- Model versions in 60 Hz.
- Marine versions 440V III 50/60 Hz No neutral or 480V III 50/60 Hz No neutral.



TECHNICAL DATA	UNIT.	DD23 SILVER/BRONZE	
<b>CAPACITY</b>			
Capacity 1/18	Kg	26	
Capacity 1/20	Kg	23	
Hourly Output SILVER/BRONZE	Kg/h	46	
Evaporation capacity SILVER/BRONZE	l/h	23,9	
<b>DRUM</b>			
Ø Drum	mm	855	
Ø Door	mm	574	
Door center height	mm	1030	
Load hole bottom height	mm	743	
Drum length	mm	800	
Drum volume	l	460	
<b>POWER</b>			
Drum motor power	Kw	0,37	
Fan Motor Power SILVER/BRONZE	Kw	0,55	
Total Installed power SILVER/BRONZE	Kw	24,97	
Electric Heating (Installed power)	Kw	24	
Gas heating (installed Power) in KW	Kw	31	
Gas heating (installed el. power) SILVER/BRONZE	Kw	0,97	
Steam heating (Steam Power KW)	Kw	49,2	
Steam heating ( installed el. power) SILVER/BRONZE	Kw	0,97	
<b>CONNECTIONS</b>		<b>ELECTRICAL</b>	<b>STEAM / GAS</b>
Tension 230V - I + T	N° x mm2 / A	-	3 x 1,5 / 20A
Tension 230V - III + T	N° x mm2 / A	4 x 25 / 80A	4 x 1,5 / 20A
Tension 400V - III + N + T	N° x mm2 / A	5 x 10 / 40A	5 x 1,5 / 20A
Ø Gas inlet	BSP	1/2"	
Ø Steam inlet	BSP	1"	
Ø Condensed (Steam models)	BSP	1"	
<b>DIMENSIONS / PACKING DIMENSIONS</b>			
Width / Width	mm	890/970	
Depth / Depth	mm	1245/1345	
Height / Height	mm	1812/1940	
Height without heating battery	mm	-	
Net weight / Gross weight	Kg	210/230	
<b>OTHERS</b>			
Max airflow SILVER/BRONZE	m3/h	1200	
Ø Fume exhaust	mm	200	
Noise level SILVER/BRONZE	dB	65	

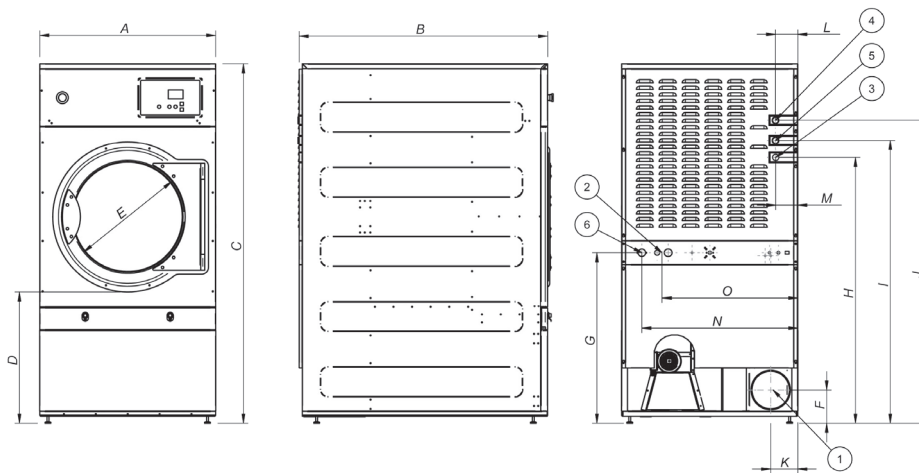

- 01. Fumes outlet
- 02. Electrical connection
- 03. Gas connection
- 04. Steam connection
- 05. Condensation outlet
- 06. Anti fire water valve

	A	B	C	D	E	F	G	H	I	J	K	L	M	N	O
DD23	890	1245	1817	672	574	168	862	1344	1430	1532	137	113	112	787	685